

TO: P1547 Ballot Group Members

FROM: Richard (Dick) DeBlasio, IEEE Standards Coordinating Committee 21 (SCC21) -- Chairman and P1547 Work Group Chairman;
P1547 Sponsor: IEEE SCC21 Chairman, Richard (Dick) DeBlasio.

SUBJECT: P1547 Draft 10 Ballot Information: ***P1547 Draft Standard For Interconnecting Distributed Resources With Electric Power Systems;***
P1547 Sponsor: IEEE SCC21 Chairman, Richard (Dick) DeBlasio.

DATE: August 27, 2002.

Dear Colleagues,

The following information is presented to help understand the development of the P1547 draft standard. The P1547 Draft 10 standard was recently completed by an expanded P1547 writing group (see table at end of this note) at the June 4 – 7, 2002 P1547 meeting. At the June meeting, the participants discussed final refinements to the P1547 Draft 9 resulting in their agreement that they thought the final P1547 draft would be sufficient to move forward with an IEEE ballot on P1547.

The P1547 Draft 10 documents the mandatory, minimum, functional technical requirements that are universally needed to help assure a technically sound interconnection. As with any standard, you need to read and understand the P1547 document as a whole before attempting to use it. And, you should understand the classification and structure of IEEE standards; IEEE standards include the following classifications (from *IEEE-SA Standards Board Operations Manual*, <http://standards.ieee.org/guides/opman/sb-om.pdf>)

- **Standards:** documents with mandatory requirements.
- **Recommended Practices:** documents in which procedures and positions preferred by the IEEE are presented.
- **Guides:** documents in which alternative approaches to good practice are suggested but no clear-cut recommendations are made.

Note. Mandatory requirements are generally characterized by use of the verb “shall,” whereas recommended practices normally use the word “should.”

In addition to the above, the structure of IEEE standards documents is such that there are certain portions of an IEEE standard that are not official parts of the standard, and, that the “Introduction” of the IEEE standard is not a part of a proposed standard (see *IEEE Standards Style Manual*, <http://standards.ieee.org/guides/style>). The IEEE style manual states, for example:

- (1) “Footnotes may be included in a standard only for information, clarification, and aid in the use of the standard. Mandatory requirements shall not be included in footnotes because footnotes are not officially a part of the standard, but they shall be included in the draft that is submitted to the IEEE-SA Standards Board. “

- (2) “Informative annexes are included in a standard for information only and are not an official part of the standard itself. ...”
- (3) and, specifically for a bibliography, “Complete and current information for bibliographic entries shall be supplied by the working group. The bibliography always shall be an informative numbered annex that appears as either the first or last annex of the standard.”

In general, further information on IEEE standards can be found at the IEEE web site.

The IEEE P1547 draft standard is the first of a series of standards documents being developed by SCC21 concerning distributed resources interconnection. The titles of the additional (draft) documents in that series follow (see listing near the end of this memo for the scope and purpose of these additional IEEE standards development projects).

- IEEE P1589 *Draft Standard For Conformance Test Procedures for Equipment Interconnecting Distributed Resources With Electric Power Systems*;
- IEEE P1608 *Draft Application Guide for IEEE Std. 1547 Standard for Interconnecting Distributed Resources With Electric Power Systems*, and;
- IEEE P1614 *Draft Guide for Monitoring, Information Exchange, and Control of Distributed Resources Interconnected With Electric Power Systems*.

Since its inception, the SCC21 P1547 development activity has moved forward on a fast track basis with the unwavering support from industry, utilities, government, and general interest groups and individuals. This support has grown and evolved from the fundamental founding principles to pursue developing a P1547 standard that states the mandatory requirements that are universally needed for interconnecting, while being technology neutral and covering all sizes of distributed resources (DR). These principles have been reviewed and debated at P1547 meetings time and time again; the only major clarification being that the standard would cover aggregate size up to 10 MVA for DR connected to the distribution level of the electric power system (EPS).

Along with the growing support for an interconnection standard, the P1547 Work Group (WG) membership has greatly increased in numbers, while the fundamental principles have continued as the basis for work group development consensus. Additionally, there has been a great outpouring of other parties having expressed their interest in P1547. We have seen a multitude of comments and suggested remedies for additional content and clauses for inclusion in P1547. Many of those comments and clauses have previously been discussed in various P1547 meetings. In large part for those comments, attendees agreed the comments were technically valid and appropriate interconnection concerns that should be pursued. However, it was also determined that many of those comments extend beyond the fundamental principles debated and previously found agreeable by the P1547 work group.

Prior to this P1547 Draft 10 ballot action, there was a ballot action on P1547 Draft 7 and subsequent recirculation ballot vote on P1547 Draft 8. Those ballot results respectively achieved 91% and 96% return of ballots, a very high return indicative of the ballot group’s commitment to achieve a successful ballot action. However, each of those ballot results ended in 66% affirmatives whereas IEEE requires 75% affirmatives in order to be able to proceed to submit the draft standard to the IEEE Standards Board for their approval as an IEEE standard. This P1547 Draft 10 is a significant change from Drafts 7 and 8.

Based on consideration of all the P1547 Drafts 7 and 8 rewording proposals and ongoing comments, the following approach was undertaken to establish Draft 9. The review of Draft 8 was a pointed and focused review by the P1547 work group and ballot group members at past P1547 meetings. During those reviews it was established which clauses were aligned with the P1547 fundamentals and that state the mandatory, minimum, functional technical requirements that are universally needed to help assure a technically sound interconnection. And, it was recommended how the clauses should be revised.

The review of P1547 Draft 8 proceeded on a clause-by-clause basis. The first part of the P1547 Draft 8 review approach was to remove the information that was appropriate for other standards or documents. That type of information includes procedure requirements, application guidance, safety practices, and, supporting information such as needed for protocols, specific DR-EPS applications, equipment-specific criteria (e.g., distributed generators or distribution transformers), type-specific utility grid configurations, operational aspects, regulatory aspects, etc. The material that was removed is being considered for its recommendation under the P1589 (testing) project, or the P1608 (application guide to P1547) project, or the P1614 guide for monitoring/control project (see table below), or, for recommendation for either additional future standards projects, or recommendation for technical or regulatory review and study.

After the P1547 work group completed the first clause-by-clause review of the P1547 Draft 8, the resulting refined “P1547 outline” was again reviewed, this time for rewording recommendations toward alignment with the fundamental principles that P1547 shall state the mandatory, minimum, functional technical requirements that are universally needed to help assure a technically sound interconnection. As part of this review, the P1547 expanded writing group held three meetings to write the final wording that result in the P1547 Draft 9. The establishment of P1547 Draft 9 involved significant changes since draft 8. That P1547 Draft 9 was based on the considerations summarized above, with more details indicated in the January 31, 2002 meeting agenda/notices and minutes <http://grouper.ieee.org/groups/scc21/1547/archives/> (folder “notices” file “Notice20020131” and folder “minutes” file “P1547Minutes20020131”).”

The P1547 Draft 9 was then sent by email for comment by the P1547 work group and the past P1547 ballot group. The comments and recommended rewording that were received were compiled, and, distributed and discussed at the June 4 – 7, 2002 work group meeting. Additionally, the attendees at the June meeting provided and discussed additional comments and recommended rewording. At the June meeting, the expanded P1547 writing group participated in the open discussions and also directly interacted with individual attendees, discussing concerns and recommended rewording for the P1547 draft. Based on the writing group’s final deliberations, they arrived at the P1547 Draft 10 wording.

IEEE SCC21 Interconnection Standards Development Projects

➤ **Title: *P1547 Draft Standard For Interconnecting Distributed Resources With Electric Power Systems.***

- Scope. This Standard establishes criteria and requirements for interconnection of distributed resources (DR) with electric power systems (EPS).
- Purpose. This document provides a uniform standard for interconnection of distributed resources with electric power systems. It provides requirements relevant to the performance, operation, testing, safety considerations, and maintenance of the interconnection.

➤ **Title: *P1589 Draft Standard for Conformance Tests Procedures For Equipment Interconnecting Distributed Resources With Electric Power Systems***

- Scope. This Standard specifies the type, production, and commissioning tests that shall be performed to demonstrate that interconnection functions and equipment of a distributed resource (DR) conform to IEEE (Draft) Std P1547.
- Purpose. Interconnection equipment that connects distributed resources (DR) to an electric power system (EPS) must meet the requirements specified in IEEE (Draft) Standard P1547. Standardized test procedures are necessary to establish and verify compliance with those requirements. These test procedures must provide both repeatable results, independent of test location, and flexibility to accommodate a variety of DR technologies.

➤ **Title: *P1608 Draft Application Guide For “IEEE Draft Standard 1547 Interconnecting Distributed Resources With Electric Power Systems”***

- Scope. This Guide provides technical background and application details to support the understanding of *IEEE P1547 (Draft) Standard for Interconnecting Distributed Resources with Electric Power Systems*.
- Purpose. This document facilitates the use of IEEE P1547 by characterizing the various forms of distributed resource technologies and the associated interconnection issues. Additionally, the background and rationale of the technical requirements are discussed in terms of the operation of the distributed resource interconnection with the electric power system. Presented in the document are technical descriptions and schematics, applications guidance and interconnection examples to enhance the use of IEEE P1547.

➤ **Title: *P1614 Draft Guide for Monitoring, Information Exchange, and Control of Distributed Resources Interconnected With Electric Power Sources***

- Scope. This document provides guidelines for monitoring, information exchange, and control for distributed resources (DR) interconnected with electric power systems (EPS).
 - Purpose. This document facilitates the interoperability of one or more distributed resources interconnected with electric power systems. It describes functionality, parameters and methodologies for monitoring, information exchange and control for the interconnected distributed resources with, or associated with, electric power systems. Distributed resources include systems in the areas of fuel cells, photovoltaics, wind turbines, microturbines, other distributed generators, and, distributed energy storage systems.
-

IEEE SCC21 P1547 Writing Group Members (March 2002)			
FirstName	LastName	email	Telephone
William	Ackerman	Thomas.Ackermann@ieee.org	(610) 395-7333
Tom	Basso, Secretary	thomas_basso@nrel.gov	(303) 275-3753
Mac	Brodie	Mac.Brodie@fluor.com	(604) 488-2107
Steve	Conrad	sconrad@pnm.com	(505) 241-2642
Jim	Daley	jdaley@asco.com	(973) 966-2474
Murray	Davis	davism@dteenergy.com	(248) 427-2221
Dick	DeBlasio, Chair	richard_deblasio@nrel.gov	(303) 275-4333
Paul	Doloff	pauld@ekpc.com	(859) 744-4812 ext. 389
Tom	Duffy	tduffy@cenhud.com	(914) 486-5417
Lynnda	Ell	lell@entergy.com	(504) 576-7007
Tom	Ernst	TERNST@exchange1.mnpower.com	(218) 722-1972 ext. 2654
Dick	Friedman	nrf@rdcnet.com	(703) 356-1300 x203
Frank	Goodman	fgoodman@epri.com	(650) 855-2872
Clark	Hochgraf	c.hochgraf@ieee.org	(585) 624-6826
Joe	Koepfinger	joseph_l_koepfinger@msn.com	(412) 264-6148
Larry	Morgan	rlmorgan@Duke-Energy.com	(704) 382-4252
Gary	Olson	Gary.L.Olson@Cummins.com	(763) 574-5055
Charles	Rogers	cwrogers@cmsenergy.com	(517) 788-0027
Gary	Seifert	sei@inel.gov	(208) 526-9522
Chase	Sun	CTS1@pge.com	(415) 973-2223
Reigh	Walling	reigh.walling@ps.ge.com	(518) 385-5370
Chuck	Whitaker	chuckw@endecon.com	(925) 552-1330
Robert	Wichert	wichert@fuelcells.com	(916) 966-9060
Tim	Zgonena	timothy.p.zgonena@us.ul.com	(847) 272-8800 x43051

[End]

IEEE P1547/ D10

Draft Standard for Interconnecting Distributed Resources with Electric Power Systems

Sponsored by the
IEEE Standards Coordinating Committee 21 (IEEE SCC21) on
Fuel Cells, Photovoltaics, Dispersed Generation, and Energy Storage
of the IEEE Standards Association

Copyright © 2002 by the Institute of Electrical and Electronics Engineers, Inc.
Three Park Avenue
New York, New York 10016-5997, USA
All rights reserved.

This document is an unapproved draft of a proposed IEEE-SA Standard – USE AT YOUR OWN RISK. As such, this document is subject to change. Permission is hereby granted for IEEE Standards Committee participants to reproduce this document for purposes of IEEE standardization activities only. Prior to submitting this document to another standard development organization for standardization activities, permission must first be obtained from the Manager, Standards Licensing and Contracts, IEEE Standards Activities Department. Other entities seeking permission to reproduce portions of this document must obtain the appropriate license from the Manager, Standards Licensing and Contracts, IEEE Standards Activities Department. The IEEE is the sole entity that may authorize the use of IEEE owned trademarks, certification marks, or other designations that may indicate compliance with the materials contained herein.

IEEE Standards Activities Department
Standards Licensing and Contracts
445 Hoes Lane, P.O. Box 1331
Piscataway, NJ 08855-1331, USA

T. Basso, Secretary of P1547 Work Group of IEEE SCC21
National Renewable Energy Laboratory – MS1614
1617 Cole Blvd
Golden, CO, 80401-3393 USA

Introduction

(This introduction is not part of IEEE P1547 Draft Standard for Distributed Resources Interconnected with Electric Power Systems.)

This IEEE 1547 standard is the first of a series of standards documents being developed by SCC21 concerning distributed resources interconnection. The titles of the additional documents in that series follow.

- IEEE P1589 *Draft Standard For Conformance Test Procedures for Equipment Interconnecting Distributed Resources With Electric Power Systems*;
- IEEE P1608 *Draft Application Guide for IEEE Std. 1547 Standard for Interconnecting Distributed Resources With Electric Power Systems*, and;
- IEEE P1614 *Draft Guide for Monitoring, Information Exchange, and Control of Distributed Resources Interconnected With Electric Power Systems*.

This first publication of IEEE P1547 is an outgrowth of the changes in the environment for production and delivery of electricity and builds on prior IEEE recommended practices and guidelines developed by Standards Coordinating Committee 21 Fuel Cells, Photovoltaics, Dispersed Generation, and Energy Storage (SCC21), e.g., IEEE Std 929-2000 IEEE Recommended Practice for Utility Interface of Photovoltaic (PV) Systems, and Standards Coordinating Committee 23 Dispersed Storage and Generation, e.g., IEEE Std 1001-1988 Guide for Interfacing Dispersed Storage and Generation Facilities with Electric Utility Systems.

Traditionally, utility electric power systems (EPS) were not designed to accommodate active generation and storage at the distribution level. The technologies and operational concepts to properly integrate distributed resources (DR) into the existing EPS continue to be further developed to fully realize benefits and to avoid negative impacts on system reliability and safety.

There is a critical need to have a single document of consensus standard technical requirements for DR interconnection rather than having to conform to numerous local practices and guidelines. This standard addresses that critical need by providing uniform criteria, and requirements relevant to the performance, operation, testing, safety considerations, and maintenance of the interconnection.

The intent of this standard is to define the technical requirements in a manner that can be universally adopted. The universality relates not only to the technical aspects, but also to the adoption of this standard as being pertinent across a number of industries and institutions, e.g., hardware manufacturers, utilities, energy service companies, codes and standards organizations, regulators and legislators, and other interested entities.

This standard focuses on the technical specifications for, and testing of, the interconnection itself, and not on the types of the DR technologies. This standard aims to be technology neutral, although cognizant that the technical attributes of DR and the types of EPSs do have a bearing on the interconnection requirements. The addition of DR to an EPS will change the system and its response in some manner. Although this standard establishes criteria and requirements for interconnection, this standard is not a design handbook nor is it an application guideline. This standard provides the minimum functional technical requirements that are universally needed to help assure a technically sound interconnection. Any additional local requirements should not be implemented to the detriment of the functional technical requirements of this standard.

It is beyond the scope of this standard to address the methods used for performing EPS system impact studies, mitigating limitations of the Area EPS, or for addressing the business or tariff issues associated with interconnection.

Participants

At the time this standard was completed, the Standards Coordinating Committee 21, on Fuel Cells, Photovoltaics, Dispersed Generation, and Energy Storage had the following membership.

Richard DeBlasio, Chair

Thomas S. Basso, Secretary

Steve Chalmers, Vice Chair

Jerry	Anderson	Barry	Hornberger
Jay	Chamberlin	Joseph L.	Koepfinger
James M.	Daley	Benjamin	Kroposki
Douglas C.	Dawson	Robert	McConnell
N. Richard	Friedman	John	Stevens
William E.	Feero	John	Wiles
Frank	Goodman	John	Wohlgemuth
Kelvin	Hecht	Timothy P.	Zgonena

At the time this standard was completed, the Distributed Resources and Electric Power Systems Interconnection Working Group (P1547 WG) of the Standards Coordinating Committee 21 (SCC21), on Fuel Cells, Photovoltaics, Dispersed Generation, and Energy Storage had the following membership who participated in the preparation of this standard.

Richard D. DeBlasio, Chair

Joseph L. Koepfinger, Vice Chair

Frank Goodman, Vice Chair

Thomas S. Basso, Secretary

William	J.	Ackerman	Werner	M.	Blumer
Larry		Adams	Robert	E.	Boettner
J.	Reese	Adomaitis	Bogdan		Borowy
Pirous	(Pete)	Ahkami	Ward		Bower
Naeem		Ahmad	Gerry		Boyd
Richard	(Rick)	Allison	Carl	C.	Brittain
Peter		Amos	Steven	R.	Brockschink
Roger	A.	Argeñal	M.	N. (Mac)	Brodie
Martin		Baier	Bill		Brooks
Philip	A.	Baker	Jack		Brouwer
John	C.	Balachandra	Demy		Bucaneg
Philip		Barker	Brian		Bui
David		Barone	Mike		Bui
David		Bassett	David		Burnett
Alan		Bax	Michael	V.	Byrnes
Edward		Beardsworth	John J.		Bzura
Terry		Becker	Raphael		Caire
Robert	W.	Beckwith	Fernando		Calderon
Michael		Behnke	Bob		Cantwell
Stephen		Berger	Scott	Anthony	Castelaz
Michael	L. S.	Bergey	Alfonso		Centuori
Charles		Berry	Steve		Chalmers
Vijay		Bhavaraju	Jay		Chamberlin
John		Bilash	Rob	A.	Chandler
Stanley		Blazewicz	Liuchen		Chang
			Jamie		Chapman

Joe		Chau	Barry	Feldman
Simon	H.	Cheng	Ralph	Ferraro
Muhammad		Choudhry	Bob	Fick
Kurt	K.	Christensen	Tom	Field
Lloyd		Cibulka	Al	Folkman
Geoffrey	F.	Clark	Lou	Fonte
David	A.	Cohen	Harvey	Forest
Alan		Collinson	Bryan	R. Fox
Reginald		Comfort	David	Frank
David		Conover	Christopher	Freitas
Larry	E.	Conrad	Paul	J. Frey
Stephen	(Steve) P.	Conrad	N. Richard	(Dick) Friedman
William	(Bill) J.	Cook	Lisa	Gagnon
Ken	L.	Cooley	Joseph	(Joe) Galdo
Garth		Corey	Susan	Gardner
Dave	M.	Costyk	Wayne	Gardner
William	T.	Crossland	Andris	Garsils
Bob		Cunningham	Bryan	Gernet
Zaher		Daboussi	Patsy	Geske
Jeff		Dagle	Mark	Gibson
James	M.	Daley	Rick	Gilliam
Murray	W.	Davis	Thomas	C. J. Gleason
Douglas	C.	Dawson	Manuel	A. Gonzalez
Joseph		Debs	Daniel	Goodrich
Charles		DeCorse	Tom	Gordon
Michael		de'Marsi	Charles	Gougler
David	W.	Dewis	Ed	Grebel
Peter		Dick	Tom	Greely
Paul	A.	Dolloff	Jim	(Herbert) Green
Kevin	E.	Donahoe	George	T. Gurlaskie
David	N.	Dorsey	J.	H. Gurney
Michael	T.	Doyle	Lance	P. Haines
Per		Drewes	Kenneth	Hall
H.	G. (Bert)	Dreyer	Bruce	Hamilton
Roch		Ducey	Kent	M. Harmon
Thomas		Duffy	Brent	Harris
Roger	C.	Dugan	Louis	Harris
Kevin		Duggan	Ronald	D. Hartzel
Mary		Duggan	Kelvin	Hecht
John	A.	Duncan	Christy	Herig
James		Dunlop	Steve	Hester
George	A.	Earle	Clark	G. Hochgraf
Stephen	(Steve) E.	Early	Earl	W. Hodge
Michael		Edds	John	Hoffner
Lynnda		Ell	Stephen	Hogan
James	W.	Ellars	Craig	F. Holmes
Daniel	C.	Engel	Donald	L. Hornak
Neil		Engelman	Barry	Hornberger
Gary	R.	Engmann	Raymond	M. Hudson
Thomas	(Tom) W.	Ernst	Doug	Hunchuk
Davis	P.	Erwin	Michael	J. Hyland
Mark		Federle	Joe	Iannucci
William	E.	Feero	Michael	(Mike) R. Ibold

Carl		Imhoff	Jeff		McElray
Michael	R.	Ingram	Frank	R.	McElvain
Nicholas	A.	Ioannou	Tim		McIntyre
Jim	R.	Iverson	Mike		McKeon
Robert	W.	Jackson	Tron		Melzl
Robert	H.	Jones	Michael	(Mike)	Michaud
Stephen	R.	Jones	Alex		Mikonowicz
Hal		Kamigaki	Tor-Eivind		Moen
William		Kaszeta	Robert	L. (Larry)	Morgan
John	R.	Kennedy	Allen	G.	Morinec
Scott	A.	Kenner	Blake	B.	Morrison
Darrell		Kent	Jay		Morrison
Greg		Kern	David	H.	Munyan
Thomas		Key	Terrence	W.	Mysak
Carl		Keyes	Gary		Nakarado
Yuri		Khersonsky	Chet		Napikoski
Brendan		Kirby	Arun		Narang
Robb		Klashner	Jerry		Neal
Kurt		Klunder	Bradley	D. (Brad)	Nelson
Brenon		Knaggs	Kenneth	E.	Nicholson
Ljubomir	A.	Kojovic	Gary	L.	Olson
(Christopher) Todd		Kollross	Ron		Oonate
Frank		Kornbaum	Fari		Ordubadi
Burton		Krakow	Paul	A.	Orr
Kenneth		Krastins	Ernie		Palomino
Jan	F.	Kreider	David		Park
Ben		Kroposki	Alfred		Pattmann
Dale		Krummen	Fang	Zheng	Peng
Steve		Kuehl	Charles	H.	Perry
Richard	(Rick)	Langley	Jeff		Petter
Leonard	E.	Lansing	Philip	A.	Philippidis
Chris		Larsen	Michael		Pincus
Bruce	K.	Larson	Jeff	G.	Pope
Bob		Laufenberg	Edan		Prabhu
Schienbein		Lawrence	Stan		Pukash
Eric		Le Courtois	Ronald		Quick
Louis		Lefevre	Ed		Quiroz
James	W.	Lemke	Kaushik		Rajashekara
Kevin		LeRow	John	A.	Raksany
David		Leslie	Gregory	J.	Ramon
Ted		Lesster	Jim		Ranfone
Jason		Lin	Jason	N.	Richards
Richard	W.	Lincoln	George		Ritchie
William	E.	Liss	Raymond		Roberge
James		Long	George		Robinson
Kevin	P.	Loving	Charles		Rogers
Don		Lowenberg	Matt		Romanow
Carl	C.	Lower	Bob		Rose
Andrew	R.	Macko	Paul		Russell
Scott		Malinowski	Bob		Saint
Arshad		Mansoor	Daniel	P.	Sammon
Sylvain		Martel	Daniel		Sandoval
Anthony		Mazy	Juan	S.	Santos

Mark		Sardella	Elisabeth	(Betty) A.	Tobin
William	W.	Saylor	Sondra		Todd
Vince		Scaini	Dennis		Tollefson
Patrick	(Pat) K.	Scharff	Jim		Tomaseski
Joe	E.	Schatz	Ed		Torrero
Jason		Schripsema	David	L.	Townley
Charles		Schwartz	Glen		Tubrett
Gary	W.	Scott	David		Van Holde
Gary		Seifert	Mohammad		Vaziri
James		Sember	Jerry		Ventre
Edward	C.	Shaffer	Harry		Vollkommer
Michael	T.	Sheehan	Dan		Walker
Kent		Sheldon	Simon		Wall
Richard		Shiroma	Tim	(Carl T.)	Wall
Larry		Shockling	Reigh	A.	Walling
Georg	A.	Shultz	Daniel	(Dan) J.	Ward
Herbert	J.	Sinnock	Byron		Washom
Andrew		Skok	James	(Jim)	Watts
David	R.	Smith	Howard		Wenger
Jeff		Smith	Randall	(Randy)	West
Allan	D.	St. Peter	Rick		West
Wayne		Stec	Ron		Westfall
William	J.	Steeley	John	S.	Wheat
Ed		Stein	Charles		Whitaker
Jon	D.	Steinmetz	Kent		Whitfield
Dehn	A.	Stevens	Robert		Wichert
John		Stevens	John		Wiles
Robert		Stewart	Pat	A.	Wilkins
William		Stillinger	Paul	H.	Williams
Robert		Stokes	Robert		Wills
Todd	M.	Strothers	Thomas		Wind
John	V.	Stutsman	John		Wohlgemuth
Charles	R.	Sufana	Ronald		Wolk
Chase		Sun	Ronald		Wong
Len		Swanson	Murty	V. V. S.	Yalla
Craig		Taborsky	Mike		Yang
Sonal		Talati	Henry	W.	Zaininger
Larry		Tangel	Timothy	P.	Zgonena
Paula	A.	Taylor	Richard		Zhang
Dave		Tewari	Donald	(Don) W.	Zipse
Rao		Thallam	Luis		Zubieta
Tony		Thorne			

The following working group members participated in finalizing the development of the document with working group inputs, and in facilitating the development of those inputs throughout the standards development process:

William J.	Ackerman	Frank	Goodman
Thomas S.	Basso	Clark	Hochgraf
M. N. (Mac)	Brodie	Joseph L.	Koepfinger
Stephan P.	Conrad	Robert L. (Larry)	Morgan
James M.	Daley	Gary L.	Olson
Murray W.	Davis	Charles	Rogers
Richard D.	DeBlasio	Gary	Seifert
Paul A.	Dolloff	Chase	Sun
Thomas	Duffy	Reigh A.	Walling
Lynnda	Ell	Charles	Whitaker
Thomas W.	Ernst	Robert	Wichert
N. Richard	Friedman	Timothy P.	Zgonena

CONTENTS

INTRODUCTION	2
1.0 OVERVIEW.....	10
1.1 Scope.....	10
1.2 Purpose.....	10
1.3 Limitations	10
2.0 REFERENCES.....	12
3.0 DEFINITIONS AND ACRONYMS.....	13
3.1 Definitions	13
3.2 Acronyms	15
4.0 INTERCONNECTION TECHNICAL SPECIFICATIONS AND REQUIREMENTS	16
4.1 General Requirements	16
4.1.1 Voltage Regulation.....	16
4.1.2 Integration with Area EPS Grounding.....	16
4.1.3 Synchronization.....	16
4.1.4 Distributed Resources on Distribution Secondary Grid and Spot Networks.....	16
4.1.4.1 Distribution Secondary Grid Networks.....	16
4.1.4.2 Distribution Secondary Spot Networks	17
4.1.5 Inadvertent Energization of the Area EPS.....	17
4.1.6 Monitoring Provisions.....	17
4.1.7 Isolation Device.....	17
4.1.8 Interconnect Integrity	17
4.1.8.1 Protection from Electromagnetic Interference.....	17
4.1.8.2 Surge Withstand Performance.....	18
4.1.8.3 Paralleling Device.....	18
4.2 Response to Area EPS Abnormal Conditions	18
4.2.1 Area EPS Faults.....	18
4.2.2 Area EPS Reclosing Coordination	18
4.2.3 Voltage	18
4.2.4 Frequency	19
4.2.5 Loss of Synchronism	19
4.2.6 Reconnection To Area EPS.....	19
4.3 Power Quality	20
4.3.1 Limitation of DC Injection	20
4.3.2 Limitation of Flicker Induced by the DR	20
4.3.3 Harmonics.....	20

4.4	Islanding	20
4.4.1	Unintentional Islanding	20
4.4.2	Intentional Islanding.....	21
5.0	INTERCONNECTION TEST SPECIFICATIONS AND REQUIREMENTS	
	22	
5.1	Design Test	22
5.1.1	Response to Abnormal Voltage and Frequency	22
5.1.2	Synchronization.....	23
5.1.3	Interconnect Integrity Test.....	24
5.1.3.1	Protection From Electromagnetic Interference (EMI).....	24
5.1.3.2	Surge Withstand Performance	24
5.1.3.3	Paralleling Device.....	24
5.1.4	Unintentional Islanding	24
5.1.5	Limitation of DC Injection	24
5.1.6	Harmonics.....	24
5.2	Production Tests	25
5.3	Interconnection Installation Evaluation	25
5.3.1	Grounding Integration with Area Electric Power System	25
5.3.2	Isolation Device.....	25
5.3.3	Monitoring Provisions	25
5.3.4	Area EPS Faults.....	26
5.3.5	Area EPS Reclosing Coordination	26
5.4	Commissioning Tests	26
5.4.1	Unintentional Islanding Functionality Test	27
5.4.1.1	Reverse-Power or Minimum Power Test	27
5.4.1.2	Non-Islanding Functionality Test	27
5.4.1.3	Other Unintentional Islanding Functionality Tests.....	27
5.4.2	Cease to Energize Functionality Test	27
5.5	Periodic Interconnection Tests	27
	ANNEX A	28
	(INFORMATIVE)	28
	BIBLIOGRAPHY	28

P1547/D10

Draft Standard for Interconnecting Distributed Resources with Electric Power Systems

1.0 Overview

This standard provides interconnection technical specifications and requirements, and test specifications and requirements. Additionally, there is a bibliography included as annex A that lists citations referred to in this standard for informative purposes but those are not required to be used in conjunction with this standard.

1.1 Scope

This standard establishes criteria and requirements for interconnection of distributed resources (DR) with electric power systems (EPS).

1.2 Purpose

This document provides a uniform standard for interconnection of distributed resources with electric power systems. It provides requirements relevant to the performance, operation, testing, safety considerations, and maintenance of the interconnection.

The requirements shall be met at the point of common coupling (PCC), although the devices used to meet these requirements can be located elsewhere. This standard applies to interconnection based on the aggregate rating of all the DR units that are within the Local EPS. The functions of the interconnection system hardware and software that affect the Area EPS are required to meet this standard regardless of their location on the EPS.

The stated specifications and requirements, both technical and testing, are universally needed for interconnection of DR, including synchronous machines, induction machines, or power inverters/converters, and will be sufficient for most installations.¹

1.3 Limitations

The criteria and requirements in this document are applicable to all distributed resource technologies, with aggregate capacity of 10 MVA or less at the PCC, interconnected to electric power systems at typical primary and/or secondary distribution voltages. Installation of DR on radial primary and secondary distribution systems is the main emphasis of this document, although installation of DR on primary and secondary network distribution systems is considered. This standard is written considering that the DR is a 60 Hz source.

- This standard does not define the maximum DR capacity for a particular installation that may be interconnected to a single PCC or connected to a given feeder.

¹ Additional technical requirements and/or tests may be necessary for some limited situations.

- This standard does not prescribe DR self-protection or all operating requirements for DR units.
- This standard does not address planning, designing, operating, or maintaining the Area EPS.
- This standard does not apply to automatic transfer schemes in which load is transferred between the DR and the EPS in a momentary make-before-break operation provided the duration of paralleling the sources is less than 100 ms, except as noted in 4.1.4.

2.0 References

The following standards shall be used in conjunction with this standard. When the stated version of the following standards is superseded by an approved revision, then that revision shall apply.

The applicability of the following standards is determined by the specific requirements stated in this standard, such as requiring certain sections.

IEEE Std C37.90.1-1989 (R1994) IEEE Standard Surge Withstand Capability (SWC) Tests for Protective Relays and Relay Systems

IEEE Std C37.90.2 (1995) IEEE Standard Withstand Capability of Relay Systems to Radiated Electromagnetic Interference from Transceivers

IEEE Std C62.41.2-2002 IEEE Recommended Practice on Characterization of Surges in Low Voltage (1000V and Less) AC Power Circuits

IEEE Std C62.45-1992 (R2002) IEEE Recommended Practice on Surge Testing for Equipment Connected to Low-Voltage (1000V and Less) AC Power Circuits

ANSI C84.1-1995 Electric Power Systems and Equipment – Voltage Ratings (60 Hertz)

IEEE Std 100-2000, IEEE Standard Dictionary of Electrical and Electronic Terms

NEMA MG-1 (2001) Motors and Generators, Revision 2

3.0 Definitions and Acronyms

For purposes of this standard, the following terms and definitions apply. IEEE Std 100 should be referenced for terms not defined in this clause.

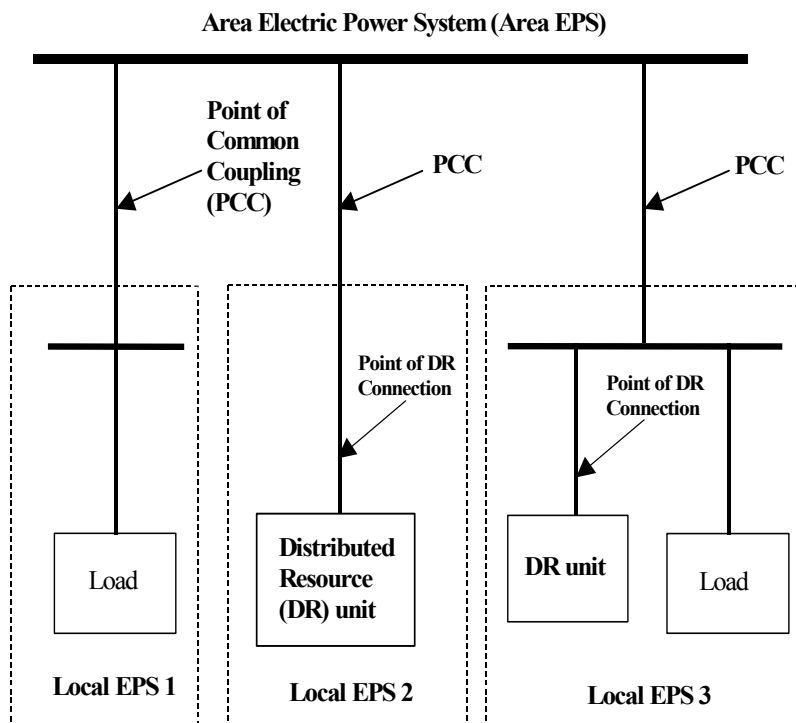

Note: Dashed lines are EPS boundaries. There can be any number of Local EPSs.

Figure 1. Relationship of Interconnection Terms.

3.1 Definitions

3.1.1 area electric power system operator (Area EPS Operator): the entity responsible for designing, building, operating and maintaining the Area EPS.

3.1.2 cease to energize: cessation of energy outflow capability.

3.1.3 design test: test of one or more devices made to a certain design to show that the design meets certain specifications.

3.1.4 distributed generation (DG): electric generation facilities connected to an Area EPS through a PCC; a subset of DR.

3.1.5 distributed resources (DR): sources of electric power that are not directly connected to a bulk power transmission system. DR includes both generators and energy storage technologies. (See Figures 1 and 2).

3.1.6 electric power system (EPS): facilities that deliver electric power to a load. Note: This may include generation units. (See Figure 1).

3.1.7 electric power system, area (Area EPS): an electric power system (EPS) that serves Local EPSs. Note. Typically, an Area EPS has primary access to public rights-of-way, priority crossing of property boundaries, etc., and is subject to regulatory oversight. (See Figure 1).

3.1.8 electric power system, local (Local EPS): an EPS contained entirely within a single premises or group of premises. (see Figure 1).

3.1.9 interconnection: the result of the process of adding a DR unit to an Area EPS. (see Figure 2).



Figure 2. Schematic of Interconnection

3.1.10 interconnection equipment: individual or multiple devices used in an interconnection system.

3.1.11 interconnection system: the collection of all interconnection equipment and functions, taken as a group, used to interconnect a DR unit(s) to an Area EPS. (see Figure 2).

3.1.12 inverter: a machine, device, or system that changes direct-current power to alternating-current power.

3.1.13 island: a condition in which a portion of an Area EPS is energized solely by one or more Local EPSs through the associated PCCs while that portion of the Area EPS is electrically separated from the rest of the Area EPS.

3.1.14 island, intentional: a planned island.

3.1.15 island, unintentional: an unplanned island.

3.1.16 non-islanding: intended to prevent the continued existence of an island.

3.1.17 point of common coupling (PCC): the point where a Local EPS is connected to an Area EPS. (See Figure 1).

3.1.18 point of distributed resources connection (point of DR connection): the point where a DR unit is electrically connected in an EPS. (See Figure 1).

3.1.19 simulated utility: an assembly of variable frequency and variable voltage test equipment used to simulate a normal utility source.

3.1.20 total demand distortion (TDD): the total root-sum-square harmonic current distortion, in percent of the maximum demand load current (15 or 30 min demand).

3.1.21 total rated-current distortion (TRD): the total root-sum-square of the current harmonics created by the DR unit operating into a linear balanced load divided by the greater of the load current demand (I_L) or the rated current capacity of the DR unit (I_{rated}).

3.2 Acronyms

3.2.1 Area EPS: Area Electric Power System

3.2.2 DG: distributed generation

3.2.3 DR: distributed resources

3.2.4 EPS: electric power system

3.2.5 I: current

3.2.5 I_L : load current

3.2.6 I_{SC} : short circuit current

3.2.7 Local EPS: local electric power system

3.2.8 PCC: point of common coupling

3.2.9 TDD: total demand distortion

3.2.10 TRD: total rated-current distortion

4.0 Interconnection Technical Specifications and Requirements

The requirements in this clause shall be met at the PCC, although the devices used to meet these requirements can be located elsewhere. The requirements apply to interconnection of either a single DR unit based on that unit's rating or multiple DR units within a single Local EPS, based on the aggregate rating of all the DR units that are within the Local EPS. The functions of the interconnection system hardware and software that affect the Area EPS are required to meet this standard regardless of their location on the EPS.

The requirements in this clause are functional and do not specify any particular equipment or equipment type.

The stated technical specifications and requirements are universally needed for interconnection of DR, including synchronous machines, induction machines, or static power inverters/converters, and will be sufficient for most installations.²

4.1 General Requirements

4.1.1 Voltage Regulation

The DR shall not actively regulate the voltage at the PCC. The DR shall not cause the Area EPS service voltage at other Local EPSs to go outside the requirements of ANSI C84.1, Range A.

4.1.2 Integration with Area EPS Grounding

The grounding scheme of the DR interconnection shall not cause overvoltages that exceed the rating of the equipment connected to the Area EPS and shall not disrupt the coordination of the ground fault protection on the Area EPS.

4.1.3 Synchronization

The DR unit shall parallel with the Area EPS without causing a voltage fluctuation at the PCC greater than $\pm 5\%$ of the prevailing voltage level of the Area EPS at the PCC, and meet the flicker requirements of clause 4.3.2.

4.1.4 Distributed Resources on Distribution Secondary Grid and Spot Networks

4.1.4.1 Distribution Secondary Grid Networks

This topic is under consideration for future revisions of this standard.

² Additional technical requirements may be necessary for some limited situations.

4.1.4.2 Distribution Secondary Spot Networks³

Network protectors⁴ shall not be used to separate, switch, serve as breaker failure backup or in any manner isolate a network or network primary feeder to which DR is connected from the remainder of the Area EPS, unless the protectors are rated and tested per applicable standards for such an application.

Any DR installation connected to a spot network shall not cause operation or prevent reclosing of any network protectors installed on the spot network. This coordination shall be accomplished without requiring any changes to prevailing network protector clearing time practices of the Area EPS.

Connection of the DR to the Area EPS is only permitted if the Area EPS network bus is already energized by more than 50% of the installed network protectors.

The DR output shall not cause any cycling of network protectors.

The network equipment loading and fault interrupting capacity shall not be exceeded with the addition of DR.

DR installations on a spot network, using an automatic transfer scheme in which load is transferred between the DR and the EPS in a momentary make-before-break operation, shall meet all the requirements of this clause regardless of the duration of parallel.

4.1.5 Inadvertent Energization of the Area EPS

The DR shall not energize the Area EPS when the Area EPS is de-energized.

4.1.6 Monitoring Provisions

Each DR unit of 250 kVA or more, or DR aggregate of 250 kVA or more at a single PCC shall have provisions for monitoring its connection status, real power output, reactive power output and voltage at the point of DR connection.

4.1.7 Isolation Device

When required by the Area EPS operating practices, a readily accessible, lockable, visible-break isolation device shall be located between the Area EPS and the DR unit.

4.1.8 Interconnect Integrity

4.1.8.1 Protection from Electromagnetic Interference

The interconnection system shall have the capability to withstand electromagnetic interference (EMI) environments in accordance with ANSI/IEEE C37.90.2. The influence of EMI shall not result in a change in state or mis-operation of the interconnection system.

³ When required by the authority who has jurisdiction over the DR interconnection, a study may be conducted to determine that all of the requirements of this clause can be met when the aggregate DR installed on a spot network exceeds 5% of the spot network's maximum load.

⁴ ANSI/IEEE C37.108-2002 and C57.12.44-2000 provide guidance on the capabilities of network systems to accept distributed resources.

4.1.8.2 Surge Withstand Performance

The interconnection system shall have the capability to withstand voltage and current surges in accordance with the environments defined in IEEE/ANSI C62.41.2 or IEEE C37.90.1 as applicable.

4.1.8.3 Paralleling Device

The interconnection system paralleling-device shall be capable of withstanding 220% of the interconnection system rated voltage.

4.2 Response to Area EPS Abnormal Conditions ⁵

Abnormal conditions can arise on the Area EPS that require a response from the connected DR. This response contributes to the safety of utility maintenance personnel and the general public, as well as the avoidance of damage to connected equipment, including the DR. All voltage and frequency parameters specified in these sub-clauses shall be met at the PCC, unless otherwise stated.

4.2.1 Area EPS Faults

The DR unit shall cease to energize the Area EPS for faults on the Area EPS circuit to which it is connected.

4.2.2 Area EPS Reclosing Coordination

The DR shall cease to energize the Area EPS circuit to which it is connected prior to reclosure by the Area EPS.

4.2.3 Voltage

The protection functions of the interconnection system shall detect the effective (RMS) or fundamental frequency value of each phase-to-phase voltage, except where the transformer connecting the Local EPS to the Area EPS is a grounded wye-wye configuration, or single phase installations, the phase to neutral voltage shall be detected. When any voltage is in a range given below (Table 1), the DR shall cease to energize the Area EPS within the clearing time as indicated. Clearing time is the time between the start of the abnormal condition and the DR ceasing to energize the Area EPS. For DR less than or equal to 30 kW in peak capacity, the voltage set points and clearing times shall be either fixed or field adjustable. For DR greater than 30 kW the voltage set points shall be field adjustable.

The voltages shall be detected at either the PCC or the point of DR connection when any of the following conditions exist:

(a) the aggregate capacity of DR systems connected to a single PCC is less than or equal to 30 kW, (b) the interconnection equipment is certified to pass a non-islanding test for the system to which it is to be connected, (c) the aggregate DR capacity is less than 50% of the total Local EPS minimum annual integrated electrical demand for a 15 minute time period, and export of real or reactive power by the DR to the Area EPS is not permitted.

Table 1. Interconnection System Response to Abnormal Voltages
--

⁵ The isolation of a portion of the Area EPS, presenting the potential for an unintended DR island, is a special concern and is addressed in clause 4.4.1.

Setting adjustments may only be made as approved by the authority who has jurisdiction over the DR interconnection.

Voltage Range (% of base voltage ^a)	Clearing Time ^b (s)
$V < 50$	0.16
$50 \leq V < 88$	2
$110 < V < 120$	1
$V \geq 120$	0.16
Notes. (a) Base voltages are the nominal system voltages stated in ANSI C84.1 Table 1. (b) $DR \leq 30kW$, Maximum Clearing Times ; $DR > 30kW$, Default Clearing Times	

4.2.4 Frequency

When the system frequency is in a range given below (Table 2), the DR shall cease to energize the Area EPS within the clearing time as indicated. Clearing time is the time between the start of the abnormal condition and the DR ceasing to energize the Area EPS. For DR less than or equal to 30 kW in peak capacity, the frequency set points and clearing times shall be either fixed or field adjustable. For DR greater than 30 kW the frequency set points shall be field adjustable.

Adjustable underfrequency trip settings shall be coordinated with Area EPS operations.

DR SIZE	Frequency Range (Hz)	Clearing Time ^a (s)
≤ 30 kW	> 60.5	0.16
	< 59.3	0.16
> 30 kW	> 60.5	0.16
	$< \{59.8 - 57.0\}$ (adjustable setpoint)	Adjustable 0.16 to 300
	< 57.0	0.16
Note. (a) $DR \leq 30$ kW, Maximum Clearing Times; $DR > 30$ kW, Default Clearing Times		

4.2.5 Loss of Synchronism

Loss of synchronism protection is not required except as necessary to meet clause 4.3.2.

4.2.6 Reconnection To Area EPS

After an Area EPS disturbance, no DR reconnection shall take place until the Area EPS voltage is within Range B of ANSI C84.1 Table 1, and frequency range of 59.3Hz to 60.5Hz.

The DR interconnection system shall include an adjustable delay (or a fixed delay of five minutes) that may delay reconnection for up to five minutes after the Area EPS steady state voltage and frequency are restored to the ranges identified above.

4.3 Power Quality

4.3.1 Limitation of DC Injection

The DR and its interconnection system shall not inject dc current greater than 0.5% of the full rated output current at the point of DR connection.

4.3.2 Limitation of Flicker Induced by the DR

The DR shall not create objectionable flicker for other customers on the Area EPS.⁶

4.3.3 Harmonics

When the DR is serving balanced linear loads, harmonic current injection into the Area EPS at the PCC shall not exceed the limits stated below (Table 3). The harmonic current injections shall be exclusive of any harmonic currents due to harmonic voltage distortion present in the Area EPS without the DR connected.

Table 3. Maximum Harmonic Current Distortion in Percent of Current ^a (I)						
Individual Harmonic Order h (Odd Harmonics) ^b	h < 11	11 ≤ h < 17	17 ≤ h < 23	23 ≤ h < 35	35 ≤ h	Total Demand Distortion (TDD)
Percent (%)	4.0	2.0	1.5	0.6	0.3	5.0
(a) I = the greater of the Local EPS maximum load current integrated demand (15 or 30 min) without the DR unit, or the DR unit rated current capacity (transformed to the PCC when a transformer exists between the DR unit and the PCC).						
(b) Even harmonics are limited to 25% of the odd harmonic limits above.						

4.4 Islanding

4.4.1 Unintentional Islanding

For an unintentional island in which the DR energizes a portion of the Area EPS through the PCC, the DR interconnection system shall detect the island and cease to energize the Area EPS within two seconds of the formation of an island.⁷

⁶ Flicker is considered objectionable when it either causes a modulation of the light level of lamps sufficient to be irritating to humans, or causes equipment mis-operation. For guidance, refer to IEEE STD 519-1992 *IEEE Recommended Practices and Requirements for Harmonic Control in Electrical Power Systems*; IEEE P1453 Draft Recommended Practice for Measurement and Limits of Voltage Flicker on AC Power Systems; International Electrotechnical Commission IEC/TR3 61000-3-7 *Assessment of Emission Limits for Fluctuating Loads in MV and HV Power Systems*; IEC 61000-4-15 *Flickermeter - Functional and Design Specifications*; and IEC 61400-21 *IEC 61400-21, Wind Turbine Generator Systems - Part 21: Measurement and assessment of power quality characteristics of grid connected wind turbines - Ed. 1.0 (2000-12)*

⁷ Some examples by which this requirement may be met are:

1. The DR aggregate capacity is less than one-third of the minimum load of the Local EPS.
2. The DR is certified to pass an applicable non-islanding test.

4.4.2 Intentional Islanding

This topic is under consideration for future revisions of this standard.

-
3. The DR installation contains reverse or minimum power flow protection, sensed between the Point of DR Connection and the PCC, which will disconnect or isolate the DR if power flow from the Area EPS to the Local EPS reverses or falls below a set threshold.
 4. The DR contains other non-islanding means such as a) forced frequency or voltage shifting, b) transfer trip, or c) governor and excitation controls that maintain constant power and constant power factor.

5.0 Interconnection Test Specifications and Requirements

This clause provides the test requirements to demonstrate that the interconnection system meets the requirements of clause 4. The applicable tests from this clause are required for all interconnection systems. The results of these tests shall be formally documented.

The stated test specifications and requirements are universally needed for interconnection of DR including synchronous machines, induction machines, or static power inverters/converters, and will be sufficient for most installations.⁸

5.1 Design Test

This design test shall be performed as applicable to the specific interconnection system technology. The test shall be performed on a representative sample, either in the factory, at a testing laboratory, or on equipment in the field.⁹

This test applies to a packaged interconnection system using embedded components or to an interconnection system that uses an assembly of discrete components.

The design test shall be conducted on the same sample in the sequence of Table 4.

Required Order	Design Test Clause and Title
1	5.1.1 Response to Abnormal Voltage and Frequency
2	5.1.2 Synchronization
3	5.1.3 Interconnect Integrity
Suggested Order	
4	5.1.1 Response to Abnormal Voltage and Frequency
5	5.1.2 Synchronization
6	5.1.4 Unintentional Islanding
7	5.1.5 Limitation of DC Injection
8	5.1.6 Harmonics

5.1.1 Response to Abnormal Voltage and Frequency

This test shall demonstrate that the DR ceases to energize the Area EPS when the voltage or frequency exceeds the limits as specified in clause 4.2.3 and clause 4.2.4. Interconnection systems provided with field adjustable set points shall also be tested at the minimum, midpoint and maximum of the adjustable set point ranges. These tests shall be conducted using either the simulated utility or secondary injection method.

⁸ Additional tests may be necessary for some limited situations.

⁹ The design test of clause 5.1 may be adopted as the testing basis for certification of interconnection systems.

5.1.2 Synchronization

Test results conforming to requirements of A, B, or C below are accepted as indicating compliance with the requirements of clause 4.1.3. The appropriate conditions to be met for specific interconnection system technology follow.

A. Synchronous Interconnection to an EPS, or an Energized Local EPS to an Energized Area EPS.

This test shall demonstrate that at the moment of the paralleling-device closure, all three parameters in Table 5 are within the stated ranges. This test shall also demonstrate that if any of the parameters are outside of the ranges stated in the table, the paralleling-device shall not close.

Table 5. Synchronization Parameter Limits for Synchronous Interconnection to an EPS, or an Energized Local EPS to an Energized Area EPS			
Aggregate Rating of DR Units (kVA)	Frequency Difference (Δf , Hz)	Voltage Difference (ΔV , %)	Phase Angle Difference ($\Delta\Phi$, °)
0 - 500	0.3	10	20
> 500 – 1,500	0.2	5	15
> 1,500 - 10,000	0.1	3	10

B. Induction Interconnection

Self-excited induction generators shall be tested as per clause 5.1.2.A above.

This test shall determine the maximum start up (in-rush) current drawn by the unit¹⁰. The results shall be used, along with Area EPS impedance information for the proposed location, to estimate the starting voltage drop and verify that the unit shall not exceed the synchronization requirements in clause 4.1.3 and the flicker requirements in clause 4.3.2.

C. Inverter Interconnection¹¹

An inverter-based interconnection system that produces fundamental voltage before the paralleling device is closed shall be tested according to the procedure for synchronous interconnection as stated in clause 5.1.2.A.

¹⁰ NEMA MG-1 contains an acceptable method for determining inrush current.

¹¹ Some inverter-based interconnection systems may need to be tested to both requirements of clause 5.1.2.C.

All other inverter-based interconnection systems shall be tested to determine the maximum startup current. The results shall be used, along with Area EPS impedance for the proposed location, to estimate the starting voltage magnitude change and verify that the unit shall meet the synchronization requirements in clause 4.1.3 and the flicker requirements in clause 4.3.2.

5.1.3 Interconnect Integrity Test

5.1.3.1 Protection From Electromagnetic Interference (EMI)

The interconnection system shall be tested in accordance with ANSI/IEEE C37.90.2 to confirm that the results are in compliance with clause 4.1.8.1. The influence of EMI shall not result in a change in state or mis-operation of the interconnection system.

5.1.3.2 Surge Withstand Performance

The interconnection system shall be tested for the requirement in 4.1.8.2 in all normal operating modes in accordance with IEEE/ANSI C62.45 for equipment rated less than 1000V to confirm that the surge withstand capability is met by using the selected test level(s) from IEEE/ANSI C62.41.2. Interconnection system equipment rated greater than 1000V shall be tested in accordance with manufacturer or system integrator designated applicable standards. For interconnection system equipment signal and control circuits use IEEE C37.90.1. The results of these tests shall indicate the unit did not fail, did not mis-operate, and did not provide mis-information.

5.1.3.3 Paralleling Device

A dielectric test across the open-circuited paralleling device shall be conducted to confirm compliance with the requirements of clause 4.1.8.3.

5.1.4 Unintentional Islanding

A test or field verification shall be conducted to confirm that clause 4.4.1 is met regardless of the selected method of detecting isolation.¹²

5.1.5 Limitation of DC Injection

Inverter based DR shall be tested to confirm that the DR does not inject DC current greater than prescribed limits that are listed in clause 4.3.1.

5.1.6 Harmonics

The intent of the harmonics interconnection test is to assess that under a controlled set of conditions the DR unit meets the harmonic limits specified in clause 4.3.3.

The DR shall be operated in parallel with a predominantly inductive voltage source with a short circuit current capacity I_{SC} of not less than 20 times the DR rated output current at fundamental frequency. The voltage and frequency output of the voltage source shall correspond to the rated voltage and frequency of the DR. The unloaded voltage waveform produced by the Area EPS or simulated utility voltage source shall have a total harmonic distortion (THD) less than 2.5 %.

¹² An example test is in UL 1741 Inverters, Converters, and Controllers for Use in Independent Power Systems.

The DR shall be operated at an output load current, I_L , of 33%, 66% and at a level as close to 100% of rated output current as practical. Use total rated-current distortion (TRD) in place of TDD. TRD is the total rms value of the sum of the current harmonics created by the DR unit operating into a linear balanced load divided by the greater of the load current (I_L) demand or the rated current capacity of the DR unit (I_{rated}). The individual harmonic distortion and TRD of the DR output current shall be measured for the first 40 harmonics. The harmonic current injections shall be exclusive of any harmonic currents due to harmonic voltage distortion present in the Area EPS without the DR connected. The test results shall not exceed the values in clause 4.3.3 Table 3.¹³

As an alternative, a synchronous generator DR shall be tested to meet the requirements of clause 4.3.3; either after installation or while powering a balanced resistive load and isolated from any other sources. The voltage harmonics while powering a resistive load at 100% of the machine kVA rating shall not exceed the levels in Table 6. Voltage harmonics shall be measured line to line for 3-phase/3 wire systems, and line to neutral for 3-phase/4-wire systems.

Individual harmonic order	$h < 11$	$11 \leq h < 17$	$17 \leq h < 23$	$23 \leq h < 35$	$35 \leq h$	Total Harmonic Distortion
Percent (%)	4.0	2.0	1.5	0.6	0.3	5.0

5.2 Production Tests

Each interconnection system shall be subjected to requirements of clause 5.1.1 and clause 5.1.2. Interconnection systems with adjustable setpoints shall be tested at a single set of setpoints as specified by the manufacturer. This test may be conducted as a factory test or may be performed as part of a commissioning test (see clause 5.4).

5.3 Interconnection Installation Evaluation

5.3.1 Grounding Integration with Area Electric Power System

A system design verification shall be made to ensure that the requirements of clause 4.1.2 have been met.

5.3.2 Isolation Device

A system design verification shall be made to ensure that the requirements of clause 4.1.7 have been met.

5.3.3 Monitoring Provisions

A system design verification shall be made to ensure that the provisions for monitoring are in accordance with clause 4.1.6.

¹³ These values or lower values may be required to meet the TDD of 5% at the PCC.

5.3.4 Area EPS Faults

A system design verification shall be made to ensure that the requirements of clause 4.2.1 have been met.

5.3.5 Area EPS Reclosing Coordination

A system design verification shall be made to verify the interconnection system is coordinated with the Area EPS reclosing practices in accordance with clause 4.2. 2.

5.4 Commissioning Tests

All commissioning tests shall be performed based on written test procedures.¹⁴ The following visual inspections shall be performed.

- A visual inspection shall be made to ensure that the grounding coordination requirement of 4.1.2 has been implemented.
- A visual inspection shall be made to confirm the presence of the isolation device if required by 4.1.7.

Initial commissioning tests shall be performed on the installed DR and interconnection system equipment prior to the initial parallel operation of the DR. The following tests are required:

- Operability test on the isolation device.
- Unintentional-Islanding functionality as specified in clause 5.4.1.
- Cease to energize functionality as specified in clause 5.4.2
- Any tests of clause 5.1 that have not been previously performed on a representative sample and formally documented
- Any tests of clause 5.2 that have not been previously performed.

The applicable tests of clause 5.1 shall be repeated when:

- Functional software or firmware changes have been made on the interconnection system
- Any hardware component of the interconnection system has been modified in the field, or, replaced or repaired with parts different from the tested configuration.

The clause 5.4.1 and clause 5.4.2, and the applicable tests of clause 5.2 shall be repeated if:

¹⁴ Test procedures are commonly provided by equipment manufacturer(s) or system integrator(s) and approved by the equipment owner and Area EPS operator.

- Protection settings have been changed after factory testing
- Protection functions have been adjusted after the initial commissioning process.

5.4.1 Unintentional Islanding Functionality Test

5.4.1.1 Reverse-Power or Minimum Power Test

A reverse-power or minimum power function, if used to meet the requirements of clause 4.4.1, shall be tested using injection techniques or by adjusting the DR output and local loads to verify that the reverse power or minimum power function is met.

5.4.1.2 Non-Islanding Functionality Test

For non-islanding interconnection systems, clause 5.4.2 satisfies this requirement.

5.4.1.3 Other Unintentional Islanding Functionality Tests

If tests in 5.4.1.1 and 5.4.1.2 are not applicable to the interconnection system, , the interconnection system shall be tested in accordance with procedures provided by manufacturer or system integrator .

5.4.2 Cease to Energize Functionality Test

Check the cease to energize functionality by operating a load interrupting device and verify the equipment ceases to energize its output terminals and does not restart/reconnect for the required time delay. The test shall be performed on each phase individually. This test verifies conformance to the cease to energize requirement of clauses 4.1.4, 4.2.1, 4.2.2, 4.2.3, 4.2.4, and 4.4.1.

5.5 Periodic Interconnection Tests

All interconnection-related protective functions and associated batteries shall be periodically tested at intervals specified by the manufacturer, system integrator, or the authority who has jurisdiction over the DR interconnection. Periodic test reports or a log for inspection shall be maintained.

Annex A

(informative)

Bibliography

The following citations are referred to in this standard for informative purposes and are not required to be used in conjunction with this standard.

- [B1] IEC TR3 61000-3-7 Assessment of Emission Limits for Fluctuating Loads in MV and HV Power Systems
- [B2] IEC 61000-4-15 Flickermeter - Functional and Design Specifications
- [B3] IEC 61400-21, Wind Turbine Generator Systems - Part 21: Measurement and Assessment of Power Quality Characteristics of Grid Connected Wind Turbines - Ed. 1.0 (2000-12)
- [B4] IEEE Std 519-1992 IEEE Recommended Practices and Requirements for Harmonic Control in Electrical Power Systems
- [B5] IEEE Std 929-2000 IEEE Recommended Practice for Utility Interface of Photovoltaic (PV) Systems
- [B6] IEEE Std 1001-1988 Guide for Interfacing Dispersed Storage and Generation Facilities with Electric Utility Systems
- [B7] IEEE Std C37.108-1989 (R2002), IEEE Guide for the Protection of Network Transformers
- [B8] IEEE Std C57.12.44-2000, IEEE Standard Requirements for Secondary Network Protectors
- [B9] UL 1741 Inverters, Converters, and Controllers for Use in Independent Power Systems
- [B10] IEEE Std Draft P1453 Draft Recommended Practice for Measurement and Limits of Voltage Flicker on AC Power Systems
- [B11] IEEE Std Draft P1589 Draft Standard For Conformance Test Procedures for Equipment Interconnecting Distributed Resources With Electric Power Systems
- [B12] IEEE Std Draft P1608 Draft Application Guide for IEEE Std. P1547 Draft Standard for Interconnecting Distributed Resources With Electric Power Systems
- [B13] IEEE Std Draft P1614 Draft Guide for Monitoring, Information Exchange, and Control of Distributed Resources